

# C105 – CombiForm Screed Rail

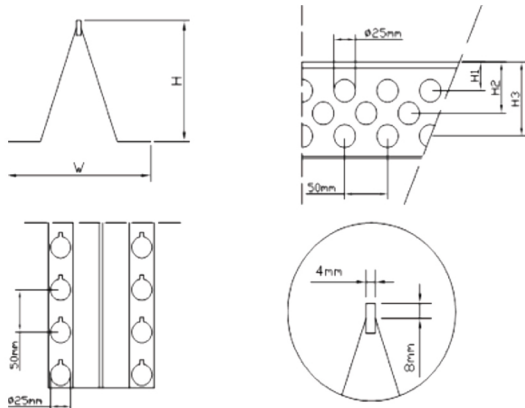

- Minimum slab depth:  
 $105 + 1,5 \times \text{max stone diameter} = \dots\dots\dots \text{mm}$   
 (i.e.  $105 + 1,5 \times 20 = 135 \text{ mm} \Rightarrow$  minimum 135 mm slab depth))  
 Recommended max slab depth: 140 mm
- Material: Steel 1 mm thick & PE plastic strip
- Crack allocation control
- Easy and accurate levelling
- Static load capacity 400 kg (support c-c 1100 mm)
- Temperature range -30°C - +80°C
- True Joint – Dowel bar holder
- Form system

Art.no	H(mm)	W(mm)	H1(mm)	H2(mm)	H3(mm)	Length(mm)	Weight/rail (kg)
23C10535	105	130	32	53	88	3500	5,6
23C10522	105	130	32	53	88	2200	3,5

## Recommended accessories

- Locking clips for reinforcing and assuring height of the profile (included in std 35 m box)
- Adjustment screws for easy and quick alignment
- Ground plate to ensure stable support
- Top extending list, 30 mm, for extra thick concrete layer &/or design.
- Adjustment tool for easy levelling

